



RECESSED LUMINAIRE INSTALLATION INSTRUCTIONS

GENERAL INSTALLATION

WARNING

To Reduce Risk Of Death, Injury, Or Property Damage From Fire, Electric Shock And Other Hazards:

The service of equipment must be performed by qualified personnel.

Installation and maintenance must be performed by qualified personnel familiar with the construction and operation of this product and any hazards involved. All applicable local and national codes and ordinances must be followed.

Read this document before installing, servicing or, maintaining this equipment. These instructions do not cover all installation, service, and maintenance situations. If your situation is not covered, or, if you do not understand these instructions or need additional information, contact American Linear Lighting or your local American Linear Lighting distributor.

WARNING

Before Installing, Servicing Or Maintaining This Equipment, Follow These General Precautions To Reduce The Risk Of Electrocutation:

Make sure the equipment is properly grounded.

Always de-energize the circuit and/or equipment before connecting to, disconnecting from, or servicing the equipment.

To Prevent Luminaire Row From Over-Current:

By adding the input current of each luminaire section marked on the luminaire, the total current per power feed must not exceed the maximum line wire amperage rating in the luminaire and the power feed cord/wire amperage rating whichever is least.

CAUTION

It Is The Installers Responsibility To Ensure That Ceiling Structurally Capable Of Supporting The Weight Of Luminaire/ Luminaire Row.

FIXTURE MOUNTING

Pages 2 - 4

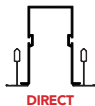

DIRECT

OFF-GRID

Pages 5 - 7



OVERLAPPING FLANGE (OF)

ON-GRID

Pages 8 - 10

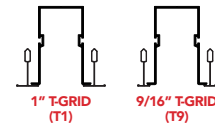

1" T-GRID (T1)

9/16" T-GRID (T9)

SAVE THESE INSTALLATION INSTRUCTIONS

SELECTING LUMEN OUTPUT AND COLOR TEMPERATURE

Step One:

Locate and remove CCT and Lumen output reminder sticker. Discard.

Step Two:

On the back of the fixture, locate the white, circular switch that controls the color temperature and lumen output. Using the black toggle switches, select the desired color temperature and lumen output. Possible selections are outlined in the reference table below.

Step Three:

Install fixture as in remaining pages of installation guide.

SELECTABLE SWITCH LOCATION DETAIL

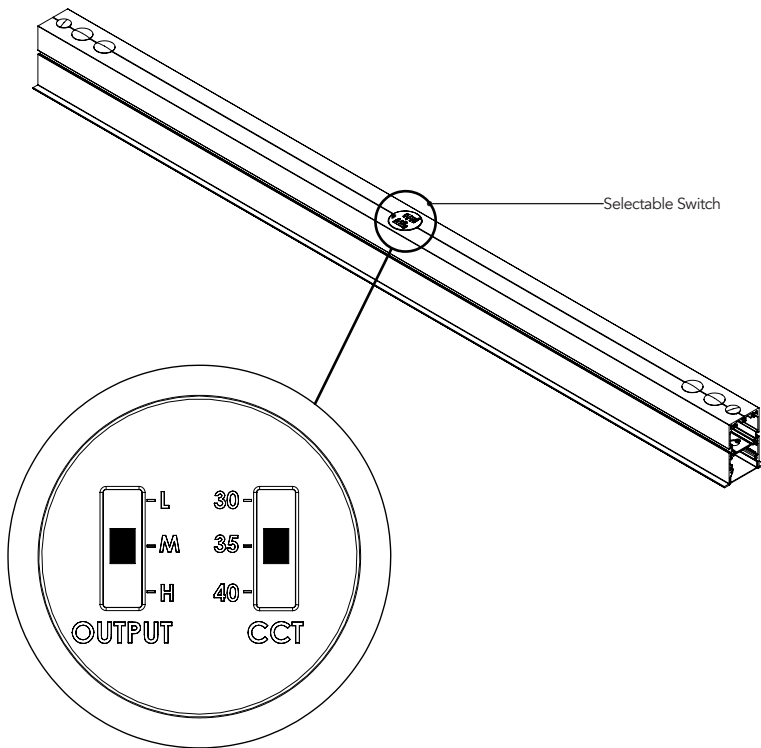

LUMEN OUTPUT AND COLOR TEMPERATURE REFERENCE TABLE

Lumen Output		Color Temperature	
L	700 Lm/Ft	30	3000K
M	900 Lm/Ft	35	3500K
H	1200 Lm/Ft	40	4000K

FIXTURE ROW LAYOUT: SINGLE UNIT 4' - 8'

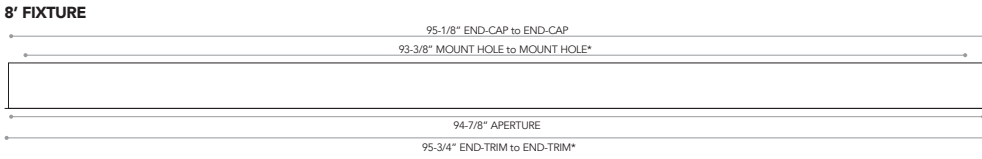
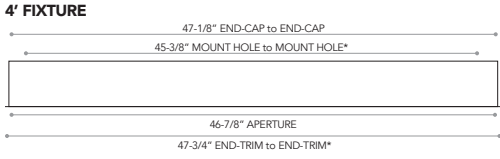

FIXTURE ROW LAYOUT: TWO UNITS 12' - 16'

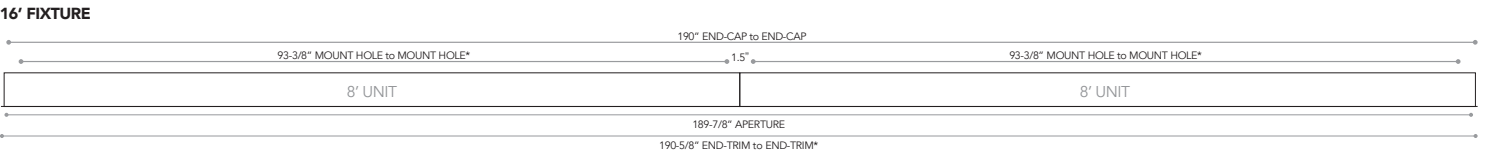
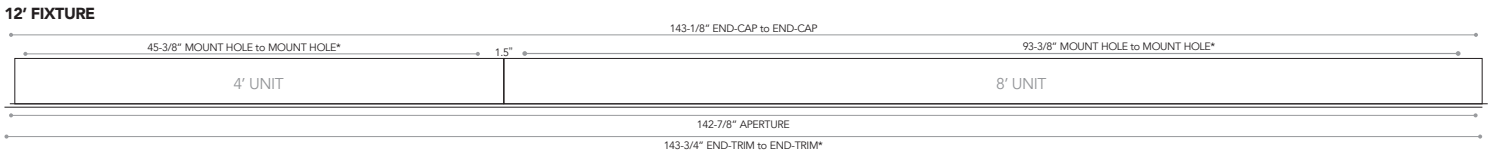

FIXTURE ROW LAYOUT: THREE UNITS 20' - 24'

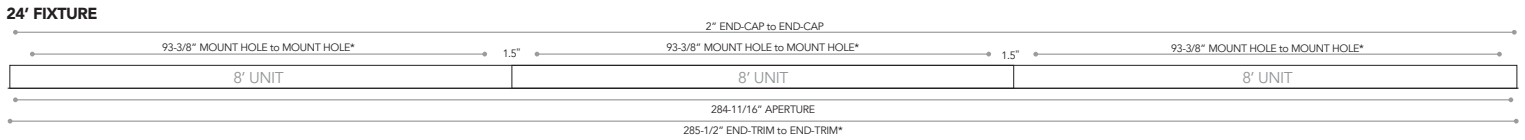
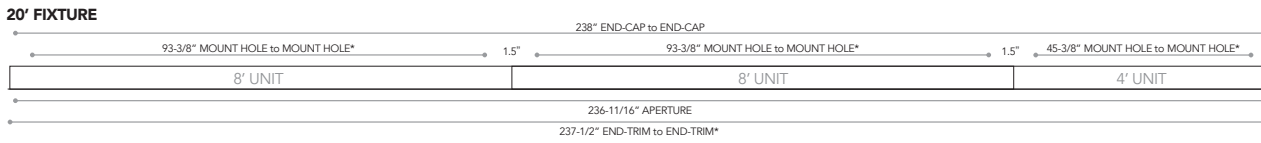

FIXTURE ROW COMPONENTS

ROW LENGTH	4'	8'	JOINT KITS	APERTURE	END-CAP TO END-CAP	END-TRIM TO END-TRIM		END-TRIM LENGTH	CEILING CUT-OUT LENGTH
				FLANGE & GRID	FLANGE & GRID	OVERLAP FLANGE	GRID	GRID (EACH SIDE)	
4'	1	-	-	46-7/8"	47-1/4"	47-3/4"	47-3/4"	-	47-1/2"
8'	-	1	-	94-7/8"	95-1/4"	95-3/4"	95-3/4"	-	95-1/2"
12'	1	1	1	142-7/8"	143-1/4"	143-3/4"	143-3/4"	-	143-1/2"
16'	-	2	1	189-3/4"	190-1/8"	190-5/8"	191-3/4"	1-00"	191-00"
20'	1	2	2	236-11/16"	237-1/16"	237-9/16"	239-3/4"	1-00"	237-15/16"
24'	-	3	2	284-5/8"	285-00"	285-1/2"	287-3/4"	1-1/2"	285-7/8"
28'	1	3	3	331-5/8"	332-00"	332-1/2"	335-3/4"	2-1/8"	332-7/8"
32'	-	4	3	379-5/8"	380-00"	380-1/2"	383-3/4"	2-1/8"	380-7/8"
36'	1	4	4	426-1/2"	426-7/8"	427-3/8"	431-3/4"	2-5/8"	427-3/4"
40'	-	5	4	474-1/2"	474-7/8"	475-3/8"	479-3/4"	2-5/8"	475-3/4"
44'	1	5	5	521-7/16"	521-13/16"	522-5/16"	527-3/4"	3-3/16"	522-11/16"
48'	-	6	5	569-7/16"	569-13/16"	570-5/16"	575-3/4"	3-3/16"	570-11/16"
52'	1	6	6	616-3/8"	616-3/4"	617-1/4"	623-3/4"	3-3/4"	617-5/8"
56'	-	7	6	664-3/8"	664-3/4"	665-1/4"	671-3/4"	3-3/4"	665-5/8"
60'	1	7	7	711-1/4"	711-5/8"	712-1/8"	719-3/4"	4-1/4"	712-1/2"
64'	-	8	7	759-1/4"	759-5/8"	760-1/8"	767-3/4"	4-1/4"	760-1/2"
68'	1	8	8	806-1/8"	806-1/2"	807-00"	815-3/4"	4-3/4"	807-3/8"
72'	-	9	8	854-1/8"	854-1/2"	855-00"	863-3/4"	4-3/4"	855-3/8"

Note 1
Flange Mount Fixtures have Mounting Holes 7/8" from End-Cap

Note 2
Flange Mount Fixture Rows Consisting of Multiple Units (16'-72') have 1.5" O.C. Between Mounting Holes at Fixture Joints

Note 3
For rows over 12', Score along the groove and break off the extra sections of the end caps to match the dimension in the table.

Note 4
Ceiling cut-out width is 2-3/8" for 2" Product and 3-3/8" for 3" Product

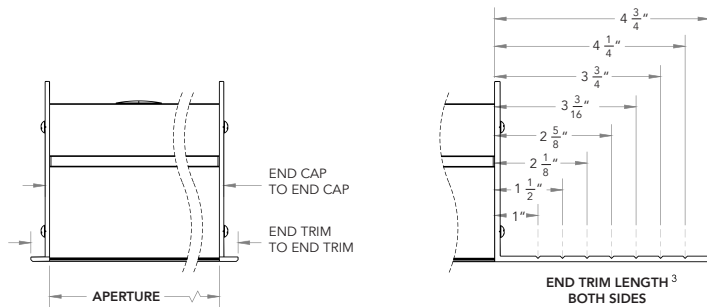

INDIVIDUAL LUMINAIRE INSTALLATION "OFF GRID" HARD CEILINGS

CAUTION:

Ceiling contractors must provide an uninterrupted continuous rough opening maintaining straightness and width. See page 2 for dimensions. Fixtures should be secured to structure above to support the weight of the fixture. Consult factory for fixture weights if needed.

Overlapping Flange (OF):

Linear luminaires intended for "Sheet Rock" are to be installed with threaded rod to structure provided above "by others". The product and should be installed in accordance with these instructions.

Step One:

Remove the lens and LED tray and safely store aside. Using one of the 7/8" dia. holes on the end fixture, install conduit connector. Install fixture into the ceiling from below into ceiling opening following instructions within this document. Mounting holes are located on the backside "housing top" for supporting to structure above. Mounting hardware by others.

Step Two:

Attach supports to fixture through holes provided and to structure above as shown (FIG. 1). Confirm that fixture is pulled up firm to ceiling line.

Step Three:

Wire to leads provided in the wiring compartment. Supply connection & splice inspection to be made by removing the lens and LED tray. Replace LED tray and lens when complete.

FIGURE 1

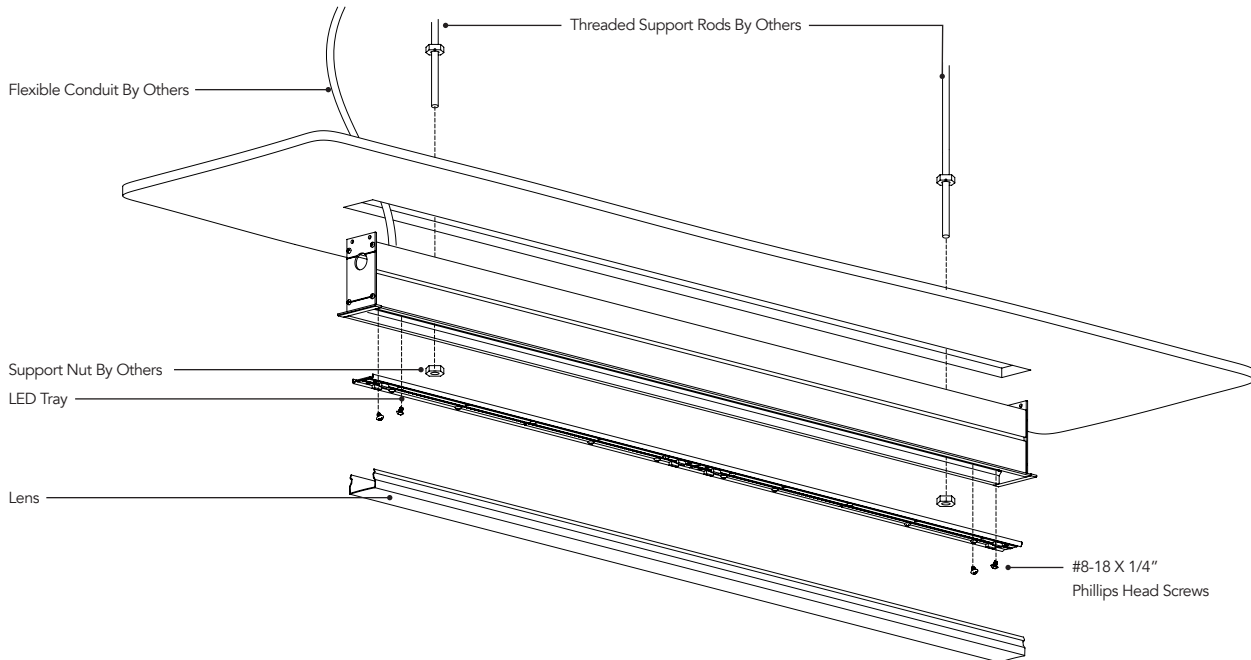

CONTINUOUS ROW LUMINAIRE INSTALLATION "OFF GRID" HARD CEILINGS

CAUTION:

Attempt to assemble fixture rows on ground and lifting row into position may create stress at connection points and may result in damage and/or mechanical failure. It is best to perform the following tasks on a protective, elevated, stable surface to ease assembly and protect the fixtures (please also note this is to be done before attempting to mount the fixture run).

Overlapping Flange (OF):

Linear luminaires intended for "Sheet Rock" are to be installed with threaded rod to structure above "by others". The product and should be installed in accordance with these instructions.

Step One:

Ceiling contractors must provide an uninterrupted continuous rough opening maintaining straightness and width. See page 3 for dimensions. Fixtures should be secured to the structure above to support the weight of the fixture run. Consult factory for fixture weights if needed.

Step Two:

Locate and install End Plate Kits and Joiner Kits (FIG. 2). See the packing list for quantities per run.

Remove the lens and LED Reflector tray(s) and store safely aside.

Attach the End Plate into the housing with (4) #6 screws from End Plate kit RH end of the fixture. (FIG. 2).

Insert 4 alignment pins and 2 alignment tabs into the housing so that they are extending out towards the fixture to be joined by 1/2" (FIG 2B). Attached the Joiner Bracket with two #10 screws positioning it so that the Center Tension Screw is located 1/16" from the edge of the housing (towards the middle of the fixture). Joining the fixture should mate easily leaving no gaps between housings.

Repeat this process for the balance of the fixtures in the run as need.

FIGURE 2

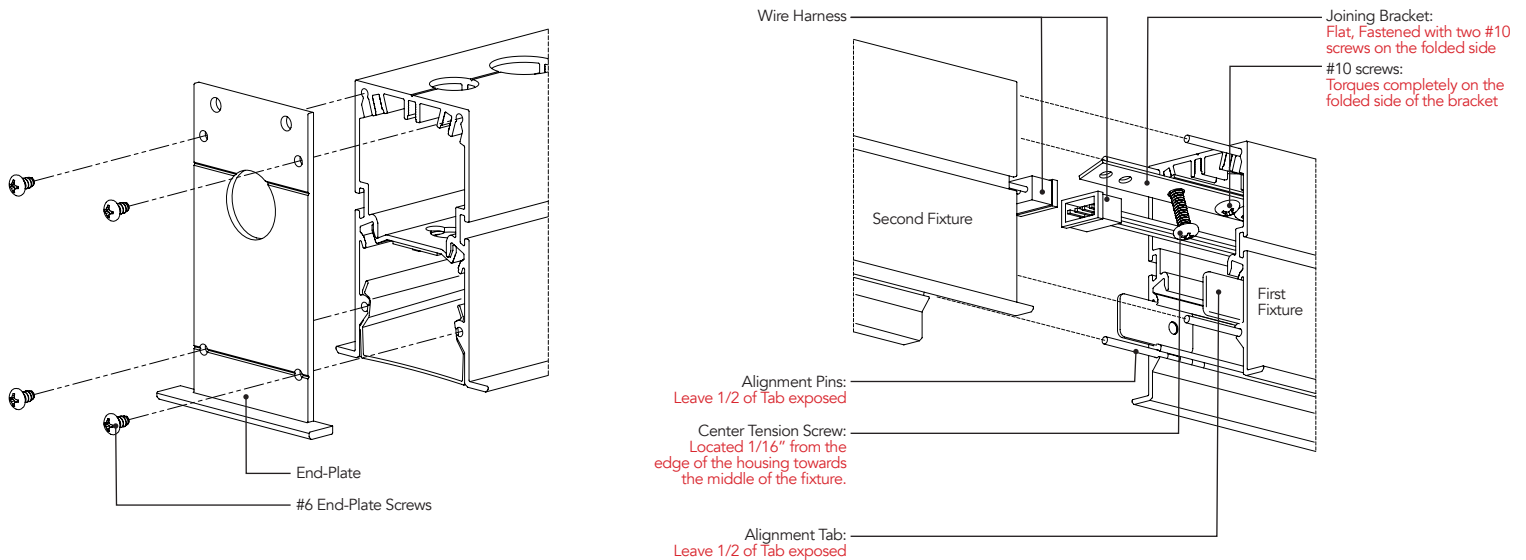

CONTINUOUS ROW LUMINAIRE INSTALLATION "OFF GRID" HARD CEILINGS

Step Three:

After determining and locating the suspension points as shown at the beginning of this document "Row Information" and following the mounting instructions provided, attach the first fixture "RH End of Row Fixture" in the row. Mounting hardware by others.

Step Four:

Position second fixture in a row (JOINER/INTERMEDIATE-ENDER) such that it aligns with the joint end of the first fixture as illustrated. (FIG.3) Make sure that all alignment hardware describes on Page 6 in (FIG. 2) are installed. It is also important to assemble an entire row on a flat, leveled, and elevated surface prior to the final ceiling installation to make sure that all alignment points fit together.

Step Five:

Continue to install and assemble row following steps 2 and 3. Using one of the 7/8" dia. holes on the Ender (LH EOR) fixture (FIG.1), install conduit connector, and wire to leads provided in the wiring compartment. When both fixtures are secured to the ceiling, screw in two #10 screws through the joining bracket plate (FIG. 3A)

Step Six:

Once all luminaires in a row are installed, tighten the Center Tention Screw on the joining bracket on all fixtures enough to hold luminaires snug to the mounting surface (FIG. 3B). Joining brackets are designed for a single-use. Contact the factory for the additional joining kits. Make a wire connection as required to meet the intended function. Reassemble LED/Reflector tray in reverse fashion and ensure that there are no wires bound by the reflector as this will cause the lens to not fit correctly. For 2" wide product line only: When reinstalling the LED tray, hold it firm in the housing tracks, screw the first screw with just a few revolutions, move to the middle, and to the last screw before screwing the first screw all the way in. Not following this step will cause the LED Tray to slide out of position and interfere with the end cap or the next fixture in a row. Please refer to Page 5 for the Wall Wash lens installation. Reinstall lens(es).

FIGURE 3

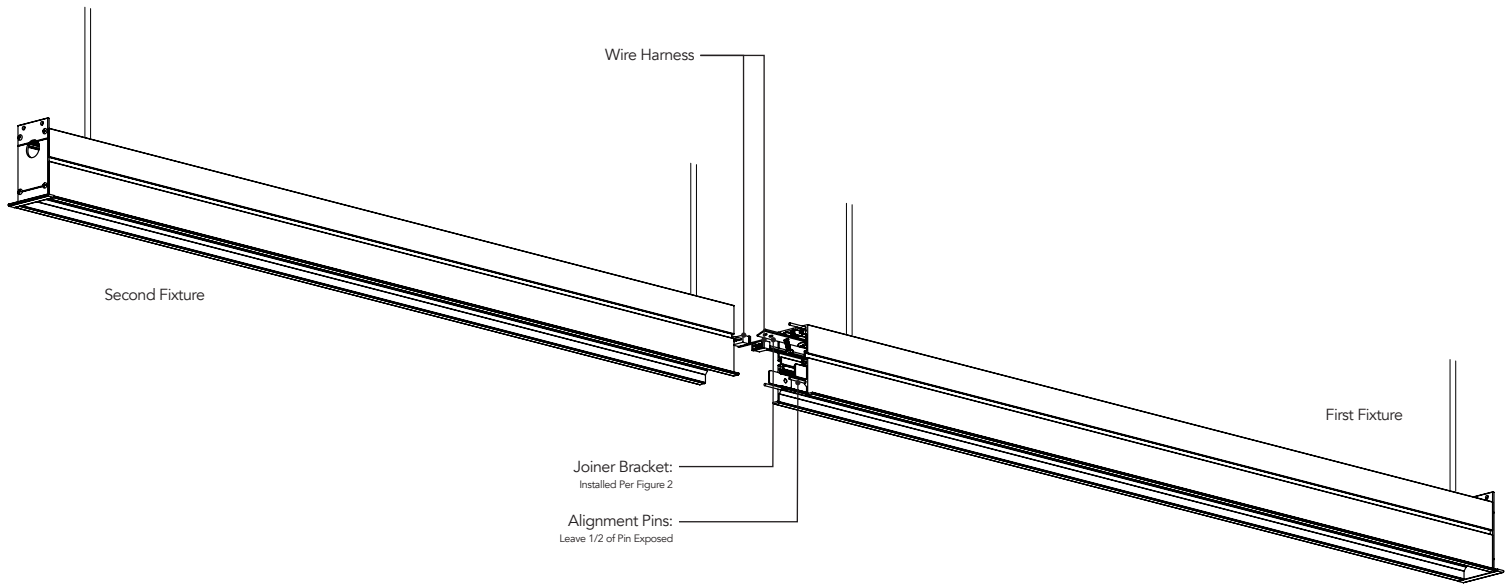

FIGURE 3A Shown in a cross-section for clarity

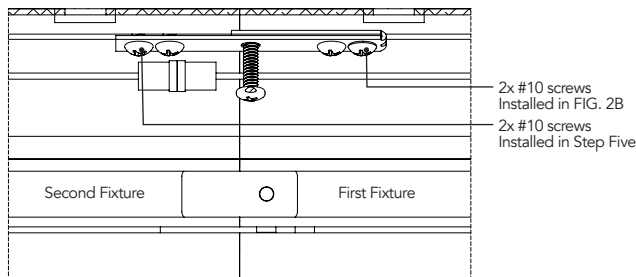
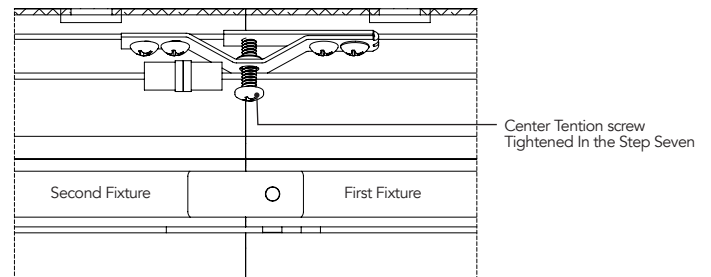

FIGURE 3B Shown in a cross-section for clarity



INDIVIDUAL LUMINAIRE INSTALLATION "ON GRID" CEILINGS

CAUTION:

Ceiling contractors must provide an uninterrupted continuous opening utilizing main tee's spaced 3" center to center. Length as required. Main tee's should be secured to structure above to support the weight of the fixture. Consult factory for fixture weights if needed.

Step One:

Remove the lens and LED tray and safely store aside (supply connection & splice inspection inside the fixture cavity). Install fixture into ceiling grid from above following instructions illustrated below, shop drawings, or order processing specification sheet. (FIG.7)

Step Two:

Attach safety wires to fixture and structure above as shown in (FIG.7).

Step Three:

Using one of the 7/8" diameter holes on the end of the fixture, install conduit connector and wire to leads provided in the wiring compartment. Supply connection and splice inspection to be made by removing lens and LED tray. Reassemble LED/Reflector tray in reverse fashion and ensure that there are no wires bound by the reflector as this will cause the lens to not fit correctly. For 2" wide product line only: When reinstalling the LED tray, hold it firm in the housing tracks, screw the first screw with just a few revolutions, move to the middle, and to the last screw before screwing the first screw all the way in. Not following this step will cause the LED Tray to slide out of position and interfere with the endplate or the next fixture in a row. Please refer to Page 5 for the Wall Wash lens installation. Reinstall lens(es).

FIGURE 7

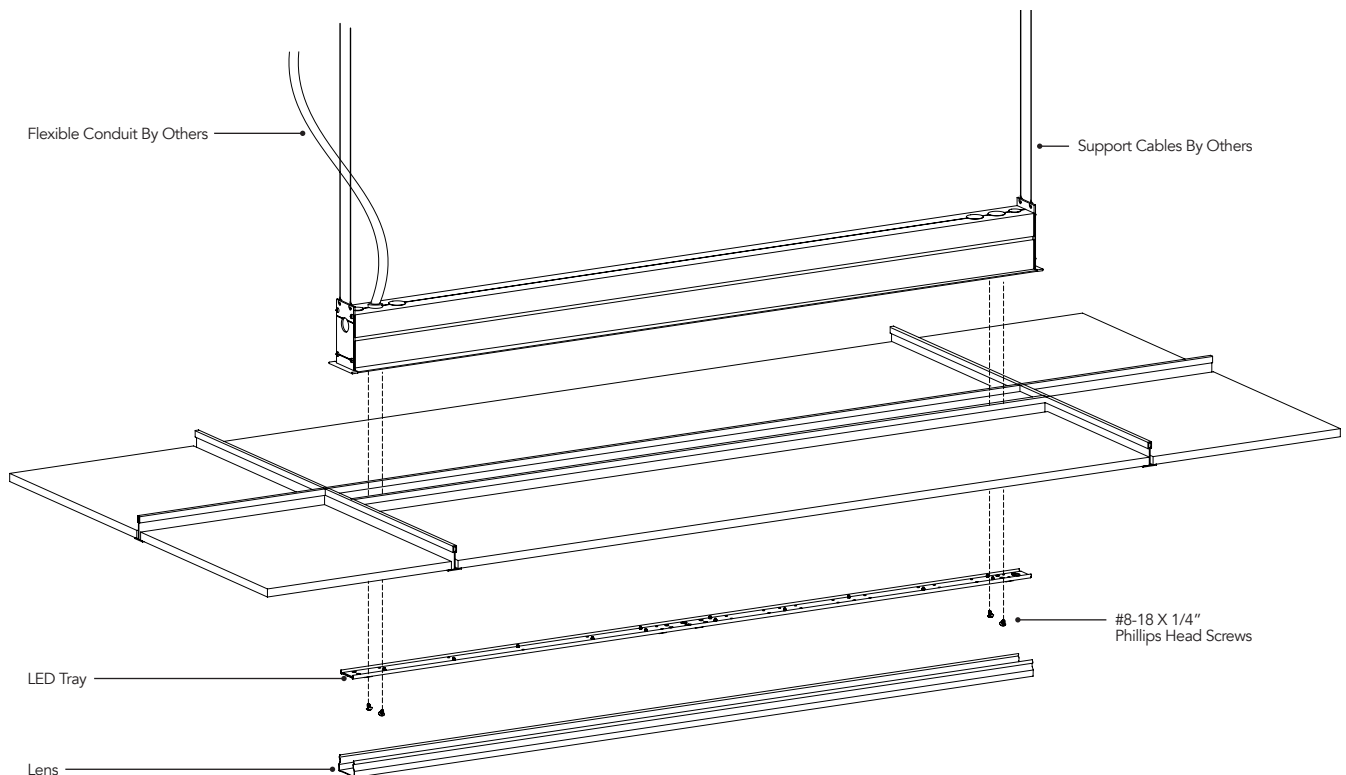

CONTINUOUS ROW LUMINAIRE INSTALLATION "ON GRID" CEILINGS

CAUTION:

Attempt to assemble fixture rows on ground and lifting row into position may create stress at connection points and may result in damage and/or mechanical failure. It is best to perform the following tasks on a protective, elevated, stable surface to ease assembly and protect the fixtures. (Please also note this is to be done before attempting to mount the fixture run).

Step One:

Ceiling contractors must provide an uninterrupted continuous opening utilizing main tee's spaced 3" center to center. Length as required. Main tee's should be secured to structure above to support the weight of the fixture. Consult factory for fixture weights if needed.

Step Two:

Locate and install End Plate Kits and Joiner Kits (FIG. 8). See the packing list for quantities per run.

Remove the lens and LED Reflector tray(s) and store them safely aside.

Attach the End Plate into the housing with (4) #6 screws from End Plate kit RH end of the fixture. (FIG. 8).

Insert 4 alignment pins and 2 alignment tabs into the housing so that they are extending out towards the fixture to be joined by $\frac{1}{2}$ " (FIG 8). Attached the Joiner Bracket with two #10 screws positioning it so that the Center Tension Screw is located $\frac{1}{16}$ " from the edge of the housing (towards the middle of the fixture). Joining the fixture should mate easily leaving no gaps between housings.

Repeat this process for the balance of the fixtures in the run as need.

FIGURE 8

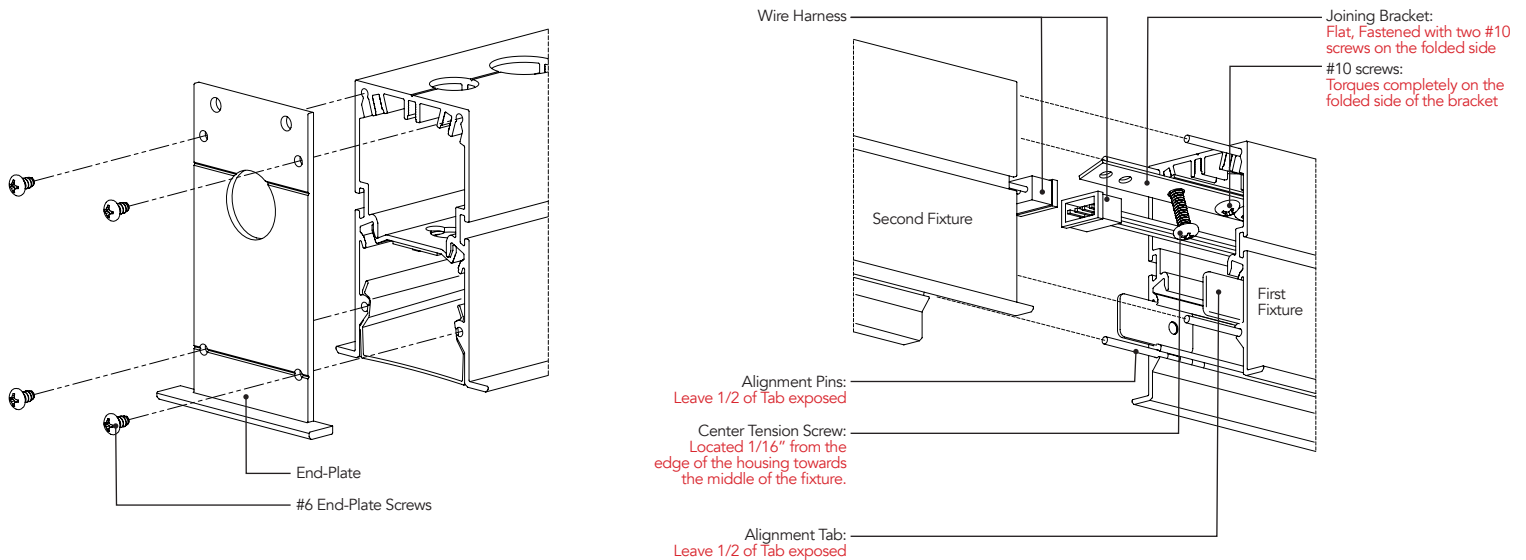

CONTINUOUS ROW LUMINAIRE INSTALLATION "ON GRID" CEILINGS

Step Three:

After locating the suspension grid requirements as shown at the end of this document "Row Information" and following the mounting instructions provided, lay the first fixture "RH End of Row Fixture" in the row.

Step Four:

Position second fixture in a row (JOINER/INTERMEDIATE-ENDER) such that it aligns with the joint end of the first fixture as illustrated. (FIG.9) Make sure that all alignment hardware describes on Page 12 in (FIG. 8) are installed. It is also important to assemble an entire row on a flat, leveled, and elevated surface prior to the final ceiling installation to make sure that all alignment points fit together.

Step Five:

Continue to install and assemble row following steps 2-4. When both fixtures are secured to the ceiling, screw in two #10 screws through the joining bracket plate (FIG. 9A)

Step Six:

Once all luminaires in a row are installed, tighten the Center Tention Screw on the joining bracket on all fixtures enough to hold luminaires snug to the mounting surface (FIG. 9B). Joining brackets are designed for a single-use. Contact the factory for the additional joining kits. Using one of the 7/8" dia. holes on the Ender (LH EOR) fixture (FIG.8), install conduit connector, and wire to leads provided in the wiring compartment. Make a wire connection as required to meet the intended function. Reassemble LED/Reflector tray in reverse fashion and ensure that there are no wires bound by the reflector as this will cause the lens to not fit correctly. For 2" wide product line only: When reinstalling the LED tray, hold it firm in the housing tracks, screw the first screw with just a few revolutions, move to the middle, and to the last screw before screwing the first screw all the way in. Not following this step will cause the LED Tray to slide out of position and interfere with the end cap or the next fixture in a row. Please refer to Page 5 for the Wall Wash lens installation. Reinstall lens(es).

FIGURE 9

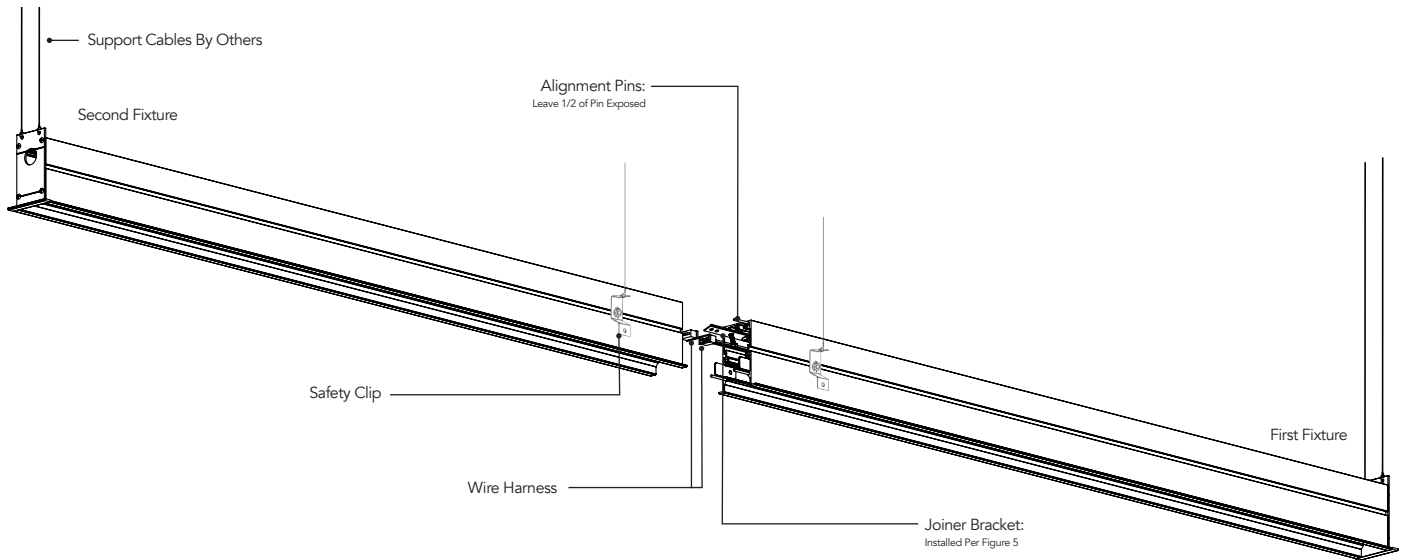

FIGURE 9A Shown in a cross-section for clarity

FIGURE 9B Shown in a cross-section for clarity

